

## Archer® | K-1123-LAW

60" x 32" alcove bath with Bask® heated surface, left drain

### Features

- Bask® heated surface creates spa-like relaxation with soothing warmth on your back, shoulders, and neck
- Three heat settings allow you to customize the surface temperature
- Comfort Depth® design offers a convenient 19" step-over height while retaining the same depth as a standard 21" bath
- Integral lumbar support
- Slotted overflow allows for deep soaking
- Integral apron
- Integral flange helps prevent water from seeping behind wall and simplifies alcove installation
- Textured bottom surface
- Coordinates with other products in the Archer collection



### Available Colors/Finishes

*Color tiles intended for reference only.*

- 0 White
- 96 Biscuit
- 95 Ice Grey



## Codes/Standards

ADA compliant when installed to the specific requirements of these regulations.



CSA B45.5/IAPMO Z124  
 ASTM E162  
 ASTM E662  
 UL 1795  
 ADA  
 ICC/ANSI A117.1  
 UL Listed

## Technical Information

All product dimensions are nominal.

Drain Location:	Left
Drain Hole Diameter:	2-1/4" (57 mm)
Minimum Flat for Door:	2-9/16" (65 mm)
Basin Area, Bottom:	45-1/8" x 19-11/16" (1146 mm x 500 mm)
Basin Area, Top:	52-3/4" x 25-5/16" (1340 mm x 643 mm)
Water Depth:	15" (381 mm)
Water Capacity:	58 gal (219.6 L)
Minimum Floor Load:	45 lbs/ft <sup>2</sup>
Weight:	80 lbs (36.3 kg)

## Material

- Acrylic

## Recommended Products/Accessories

- K-1491 Bath/whirlpool pillow, removable
- K-1601 Bath/whirlpool footstop, removable
- K-23726 Drain treatment
- K-23732 Tub & shower cleaner
- K-31795 Slotted overflow bath drain kit for above-the-floor installations
- K-31797 Slotted overflow bath drain kit

## Required Electrical Service

One circuit required, protected with Class A Ground-Fault Circuit-Interrupter (GFCI). Outside North America, this device may be known as a Residual Current Device (RCD).

Heated Surface: 120 V, 15 A

## Electrical Component Ratings

Heated Surface: 120 V, 0.5 A, 60 Hz, 65 W

## Warranty

See website for detailed warranty information.

KOHLER® Plastic Baths and Shower Bases Lifetime Limited Warranty|KOHLER® Hydrotherapy Components Five-Year Limited Warranty



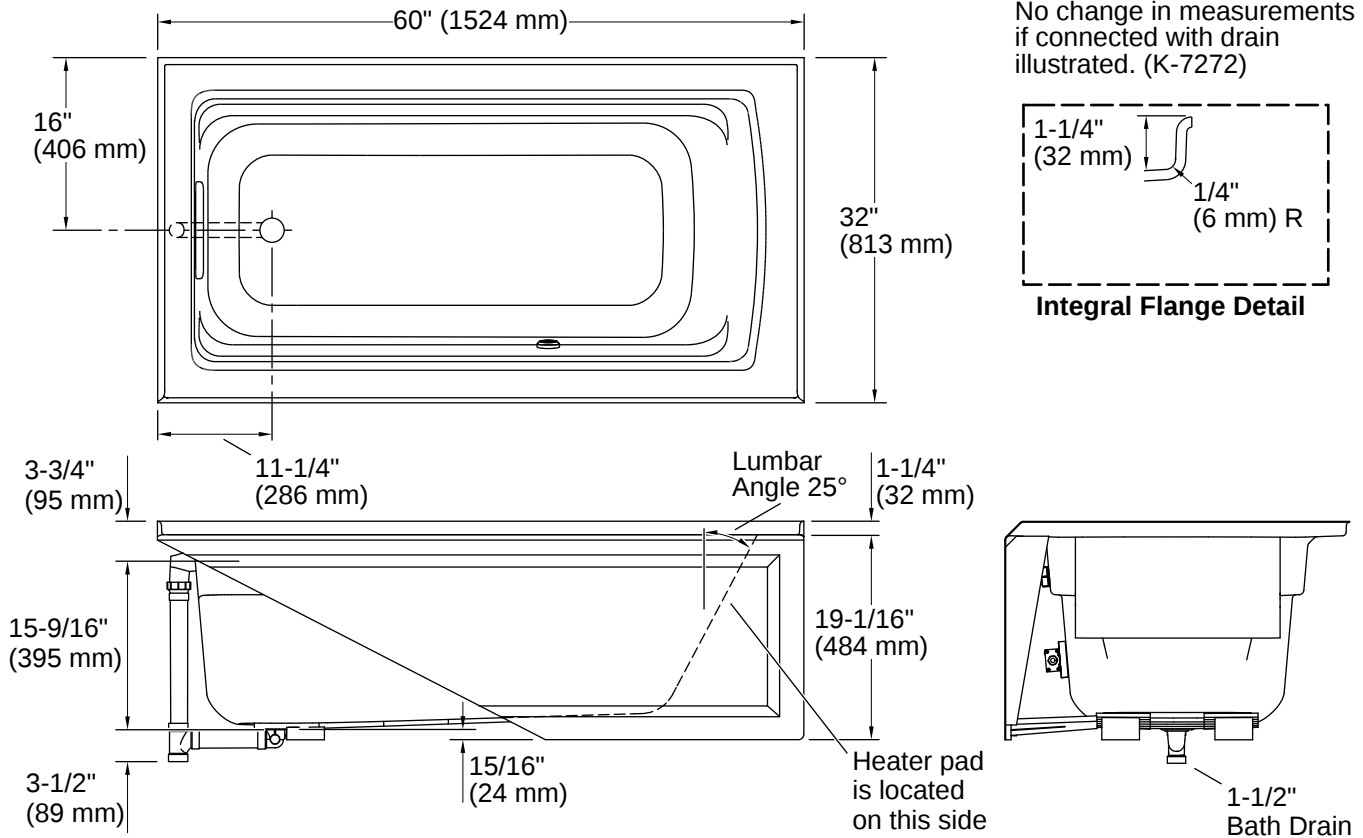

## Installation

- Left drain
- Requires Clearflo slotted overflow bath drain (sold separately)
- Alcove

## Installation Notes

*Install this product according to the installation instructions.*

Measure your actual product for rough-in details.

The hot water supply should be 70% of the capacity of the bath or greater. Installations will vary.

ADA compliant when installed to the specific requirements of these regulations.

