



Invigoration® Series | K-32333

22 kW steam generator

Features

- Fast-Response® technology produces a luxurious steam shower in 60 seconds
- Power Clean™ technology offers one-touch automatic cleaning and safe maintenance
- Constant Steam feature produces steam at a consistent rate, which greatly minimizes temperature fluctuations
- Invigoration Series steam generators use approximately one gallon of water per 20-minute session, which is significantly less water than a traditional shower experience
- 634 cubic feet maximum volume rating for custom showering applications
- To ensure safety, system automatically shuts down after 20 minutes if not reactivated by user
- For use with Invigoration steam controller with round steam heads, requires K-5558 Invigoration Series tandem steam generator control kit (sold separately)
- For use with Anthem+ or DTV+ controller with round steam heads, requires K-5549-K1 Invigoration Series tandem digital steam adapter kit (sold separately)
- For use with Invigoration steam controller with square or linear steam heads, requires K-32312 Invigoration Series steam controller, 1260090 UI controller dual generator cable kit, and choice of two K-32310 square steam heads or two K-32309 linear steam heads (all sold separately)
- For use with Anthem+ or DTV+ controller with square or linear steam heads, requires K-32311 Invigoration Series digital steam adapter, 1260089 DTV dual generator cable kit, and choice of two K-32310 square steam heads or two K-32309 linear steam heads (all sold separately)



Available Colors/Finishes

Color tiles intended for reference only.

^{NA} NA Not Applicable



1-800-4KOHLER (1-800-456-4537)

Kohler Co. reserves the right to make revisions without notice to product specifications.
For the most current specification sheet, go to www.kohler.com USA or www.kohler.ca Canada.
3-27-2026 16:25 - US-CA

THE BOLD LOOK
OF **KOHLER**®

Codes/Standards

CSA C22.2 No. 64

Technical Information

All product dimensions are nominal.

Recommended Feed Water Quality

Water Hardness: 60 ppm (4 gpg)

Total Water Alkalinity: 150 ppm

Material

- Generator is constructed of insulated stainless steel, which maintains the temperature while ensuring case is safe to the touch
-

Required Electrical Service

One dedicated circuit required.

Steam Generator: 240 V, 120 A, 50/60 Hz

Electrical Component Ratings

Steam Generator: 240 V, 60 A, 50/60 Hz

Warranty

See website for detailed warranty information.

KOHLER® Steam Generator Three-Year Limited Warranty



1-800-4KOHLER (1-800-456-4537)

Kohler Co. reserves the right to make revisions without notice to product specifications.

For the most current specification sheet, go to www.kohler.com USA or www.kohler.ca Canada.

3-27-2026 16:25 - US-CA

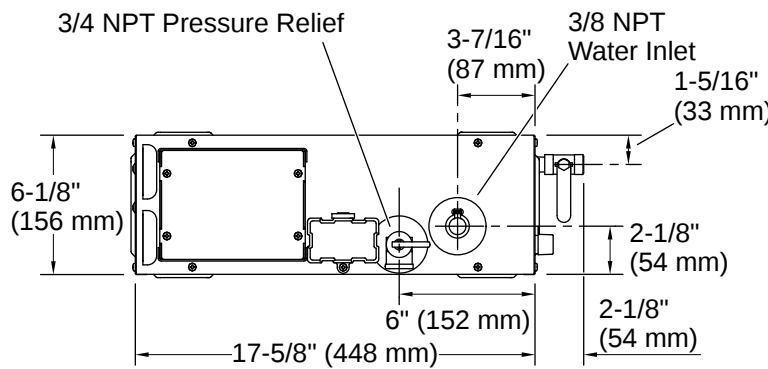

Minimum required access panel is 24" (610 mm) L x 15" (381 mm) H.

Allow for a minimum of 6" (153 mm) of space around all sides of the steam generator, with the following exception: The side opposite of the pressure relief valve may be installed against a wall.

Allow for the drain/spill pan.

KOHLER® drain pan (shown with support blocks) sold separately.

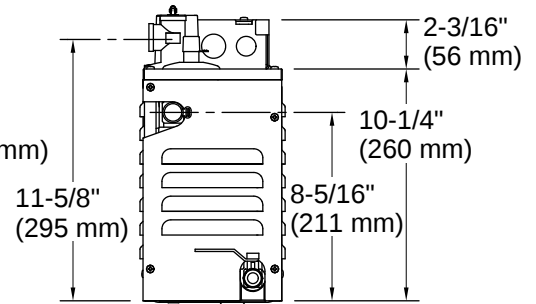
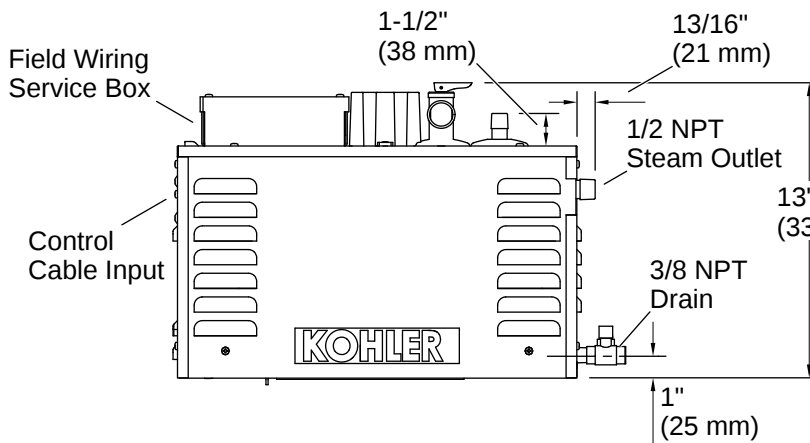

Installation Notes

Install this product according to the installation instructions.

To ensure proper operation, the feed water supply should be tested prior to operating the steam generator. If the feed water quality is not within the specific limit, contact a reputable water treatment company for treatment options.

